



ZENA-SEAL WATERPROOFING MEMBRANE



ZENITH™ INDUSTRIAL RUBBER
PRODUCTS PVT. LTD.

Quality Rubber Solutions



CONTENT

1.	Introduction	1
2.	ZENA-SEAL EPDM Waterproofing Membrane	2
3.	ZENA-SEAL EPDM Waterproofing Membrane (Zena-Bond PSA)	3
4.	Technical Specification	4-5
5.	ZAFIX (Over Lap Sealant)	6
6.	ZEP-1000 (Contact Adhesive)	7
7.	ZEBTAPE (High Performance Butyl Sealing Tape)	8
8.	ZENA-SEAL (Pond Lining)	9
9.	Application Area	10-11
10.	Features & Comparison	12-13
11.	Installation Instruction	14-15
12.	Storage & Shipping	16
13.	Achievements	17



“ Ensuring total customer satisfaction is our motto which we strive to achieve through continuous improvement in production process, upgrading the manufacturing system in line technological development, doing things right the very first time, and delivering Quality products through optimum human resources development.”

INTRODUCTION

Zenith Rubber was established in 1965 and is a leading manufacturer and exporter of rubber sheeting, flooring, coated fabrics, matting and moulded products.

In 2006, Zenith upgraded its entire manufacturing facilities and build a state of the art plant 60kms from Mumbai. Spread over 35,000 sq meters, this facility houses a completely integrated plant that has world class capabilities from compounding to dispatch of the goods, giving Zenith a complete control over its manufacturing process.

Today it enjoys the leadership status as a major exporter of quality Rubber sheets, Rubber flooring, Rubber coated fabrics & Rubber mats. Zenith is a Government Recognized Export house with present installed capacity of 90 tons of rubber compound per day.

Over 90% of its products are exported to five continents around the world. Zenith has built up a wide base of discerning customer all over the world. This has been made possible with the Zenith team of dedicated & trained personnel having earned a strong reputation of its capabilities to innovate.



ZENA-SEAL

EPDM WATERPROOFING MEMBRANE

ZENA-SEAL is a water proofing membrane developed by Zenith Rubber. The rubber membrane has 100 % EPDM polymer content making it an ideal choice for the water-proofing of roofs, swimming pool lining, ponds lining, foundations for civil constructions, soak pits for animal feed, Bio gas plants, canals lining, etc. With a life that spans 20 years ZENA-SEAL is the best choice for waterproofing applications.

ZENA - SEAL is produced in accordance to ASTM D4637 and ASTM 6134. The sheet conforms to all requirements for non-reinforced black EPDM rubber sheet for use in waterproofing applications.

DIMENSIONS

Thickness	0.75 mm to 2 mm
Width	1 Mtrs to 6 Mtrs
Length	6 Mtrs to 30 Mtrs rolls
Packing	Rolls are wrapped on 3 or 4 inch paper core with outer surface of rolls covered with HDPE

ZENA-SEAL EPDM waterproofing membranes have exceptional long-lasting elasticity permitting the materials to withstand Building movement, High resistance to Ozone, Temperature range from - 40°C to + 130°C, and Excellent steam & water resistance.





ZENA-SEAL

EPDM WATERPROOFING MEMBRANE (SA)

ZENA-SEAL EPDM Self-Adhesive is an innovative roofing membrane designed to simplify installation for roofers of varying expertise. With its distinctive factory-applied adhesive, this self-adhesive solution enables quicker and easier application. Enhance your efficiency, allowing for faster installations and increased coverage of roofing squares in a day, thereby maximizing productivity throughout the entire season.



DIMENSIONS

Thickness	0.75 mm to 1.5 mm
Width	1.5 Mtrs
Length	10 Mtrs rolls
Packing	Rolls are wrapped on 3 or 4 inch paper core with outer surface of rolls covered with HDPE



Technical Data	
Thickness (mm)	0.07mm
Release Liner	Paper, Yellow, 90 g/m ²
Adhesive Type	Modified Polyacrylate
Adhesive Weight	70 g/m ²
Adhesive Strength	21N/25 mm
Temperature Performance	-40 °C to +90 °C

TECHNICAL SPECIFICATION

EPDM MEMBRANE BASED ON ASTM - D4637

Properties	Test Method	Specification
Tolerance on Nominal Thickness,%	ASTM D 412	+/- 10%
Color	Visual	Black
Hardness	ASTM D 2240	65 ±5 Sh A
Tensile Strength (Min)	ASTM D 412	90Kg/Cm ²
Elongation At Break (Min)	ASTM D 412	300%
Tear Resistance kg/cm	ASTM D624 Method C	30kg/cm
Drop in physical properties - Ageing After 100C for 600 Hrs		
- Tensile Strength (Min)	ASTM D 412	10%
- Elongation (%)	ASTM D 412	30%
- Tear resistance (kg/cm)	ASTM D 412	15%
- Linear dimensional change max %	ASTM D 1204	+/-2%
Ozone resistance : On exposure to 100 ppm & Ozone in air 96 hrs. @40°C at 20% strain	ASTM D 1149	No crack
Glass transition Temperature	ASTM D 746	-55
Resistance Water absorption, after 7 days immersion in 70°C, % change in mass	ASTM D 471	4.0
Compression Set , 22Hrs. at 70C	ASTM D 395	30%
Specification No : ZRWP100/1	Rev. No. 9.8	Rev. No. 9.8

TECHNICAL SPECIFICATION

EPDM MEMBRANE BASED ON ASTM - 6134

Properties	Test Method	Specification
Tolerance on Nominal Thickness,%	ASTM D 412	+/-10%
Color	Visual	Black
Hardness	ASTM D 2240	65±5 Sh A
Tensile Strength (Min)	ASTM D 412	90Kg/Cm ²
Elongation at Break (Min)	ASTM D 412	300%
Abrasion Resistance (max)	ASTM D5963	250mm ³
Compression Set (70° C/24 Hrs) / (max)	ASTM D395 Method B	34%
Tear resistance (Angular) min	ASTM D624 Method c	30 kg/cm
Resistance to Heat Aging		
- Tensile Strength min.	ASTM D 412	85kgs./ CM2
- Elongation (%)	ASTM D 412	210
- Linear dimensional change max.%	ASTM D 1204	+/-1
- Brittleness temperature °C	ASTM D 746	-45
Resistance water absorption, after 166Hrs. Immersion @ 70° C		
% change in mass	ASTM D 471	4.0
Water Vapor Permeability Max. per-mills	ASTM E 96	3.5
Specification No : ZRWP100/10	Rev. No.: 9.8	Rev. No. : 9.8



ZAFIX

OVER LAP SEALANT

FEATURES & BENEFITS

DESCRIPTION – ZENA-BOND ZAFIX is single component moisture curing solvent free adhesive based on modified polymer technology. With a fusion of strong adhesion to various standard construction surfaces and excellent bond strength and flexibility, it is strongly advised for effective waterproofing applications. It can be used in damp and wet conditions thus making it as an ideal choice that you will always need this in your toolbox due to its multipurpose usage.

- Solvent Free
- Isocyanate Free
- 100% Solid
- Non Shrinkage
- Paintable
- Good Elongation

STORAGE SHELF LIFE

- Store in a cool and dry place
- Temperature should not exceed 35°C for prolonged use.
- Shelf life is up to 12 months in unopened container when stored as directed.

PACKING

ZENA-BOND ZAFIX is available in 310ml Containers.

<i>Technical Data</i>	
Curing System	Moisture Curing
Colour	White/Black/Grey
Density Approx	1.54g/mL
Skin over time	10-15
Minutes Curing time 23 C/50% RH	3-4/24 Hours
Tensile strength ASTM D412	>2.5 Mpa
Elongation at break ASTM D412	350%
Shore A Hardness ASTM C661	45 Shore A
50 Voc content	<3%
Application Temperature	5 C° To 40°C
SERVICE Temperature	-30 C To 100
Maximum joint width	-30 C To 100
MAF	25%



ZEP-1000

CONTACT ADHESIVE

FEATURES & BENEFITS

DESCRIPTION – ZEP - 1000 is single component based synthetic contact adhesive. It is specially designed for using on both porous and non-porous surfaces.

ZEP - 1000 is ideal choice for bonding EPDM water proofing membrane to concrete sub-floors, wooden-floors, geotextile for both horizontal & vertical applications.

- High grip - No Hardener required
- Easy to use and apply
- Water proof
- A Prominent choice in water proofing & constructions applications
- Can be used in multiple applications and areas

Technical Data	
Base	Solvent Base
Colour	Dark Brown
Solids Content (ASTM D 1644-01)	24+ 1 %
Viscosity (ASTM D 2196)	1500-2000 cPs
Flash Point (ASTM D 82)	<210C
Open Time	Approx. 10-25 Minutes
Temperature Resistance	-40°C to +90°C
Application	Brush, Roller

PACKING

ZENA-BOND ZEP-1000 is available in 1 Litre and 5 Litre Containers.



STORAGE SHELF LIFE

- Store in a cool and dry place
- Temperature should not exceed 30°C for prolonged use.
- Shelf life is up to 12 months in unopened container when stored as directed.



ZEB TAPE

BUTYL SEALING TAPE

DESCRIPTION – ZEB TAPE is high quality self-adhesive butyl tape from the house of ZENITH. ZEB TAPE is resistant to shrink, hardening, oxidation and in return delivers watertight sealing on metal roofs, window seal gaps, taping waterproof membranes, corner joints, roof leaks and surface cracks.

FEATURES & BENEFITS

- Cold Applications
- Easy to apply
- All weather use
- Excellent heat stability
- UV/OZONE Resistance
- Solvent Free
- Highly Flexible
- Permanent Bond

STORAGE SHELF LIFE

- Store in a cool and dry place
- Temperature should not exceed 35°C for prolonged use.
- 12 months from date of manufacturing

PACKING

ZENA-BOND Z-TAPE is available in:

STANDARD LENGTH: 10Mtr / 30Mtr.-

STANDARD THICKNESS: 1.3mm

STANDARD WIDTHS: 25mm, 50mm, 75mm and 100mm

<i>Technical Data</i>	
CHARACTERISTICS	STANDARD VALUE
Material/grade	Butyl Rubber Sealant Tape
Peel Adhesion As Per ASTM D-1000	Very Good to Ferrous, Non-ferrous & Plastics, Metals, Wood Etc
Solids - ASTM D792	100%
Heat Ageing ASTM-D573	No Flow and Cracks
Service Temperature:	35°C / 125°C
Specific Gravity ASTM D792	1.4 g/cm ² +/- 0.15MM
Tensile Strength ASTM C907	40 kg/cm ²
Shear Strength ASTM C961	1 kg
Elongation ASTM C908	400% MIN
Color	BLACK

ZENA-SEAL

POND LINING

DESCRIPTION – ZENA-SEAL EPDM pond lining membrane is known for its quality & reliability, thus making it as preferred choice for professional pond liner applicators. These heavy duty EPDM pond liners are CE certified and meets globally accepted ASTM & EN standard.

FEATURES & BENEFITS

- Robust and tough against wear and tear
- Highly elastomeric for better elongation
- Chemical resistance against aggressive groundwater conditions
- Ease to installation resulting in faster completion
- Exceptional resistance to UV, OZONE and Radiation & Safe for fishing and plants

Technical Data

Physical Property	Test Method	Zena-Seal Values 1.14/1.2 mm	Zena-Seal Values 1.5 mm
Colour		Black	Black
Thickness (mm)	ASTM D-412	1.14	1.50
Tensile Strength (MPa)	ASTM D-412	9	9
Elongation Ultimate (%)	ASTM D-412	375	350
Angular Tear (kN/m)	ASTM D-624 C	28	30
Tensile Set (%)	ASTM D-412	Pass	Pass
Brittleness Point Max "F" (°C)	ASTM D-2137	No Cracks	No Cracks
Ozone Resistance	ASTM D-1149	No Cracks	No Cracks
Resistance to Heat Aging After 100°C for 168 Hrs	ASTM D-573		
- Tensile Strength MPa	ASTM D-412	9	9
- Elongation Ultimate (%)	ASTM D-412	260	250
- Angular Tear (kN/m)	ASTM D-624	Pass	Pass
- Liner Dimension Change (%)	ASTM D-1204	0.35	0.35
- Water Absorption	ASTM D-471	Pass	Pass
- Visual Inspection	ASTM G-151	Pass	Pass

APPLICATION AREAS (ZENA-SEAL -ZSWP100)



EPDM WATERPROOFING MEMBRANE

“EPDM Waterproofing for roof systems need to withstand a lot of changing weather conditions and structural & mechanical influences. EPDM rubber has been used successfully to waterproof large commercial buildings for more than thirty years and are also recommended for commercial roofs, making its surface stronger and less likely to crack during extreme weather conditions”.

WALL PROTECTION

“Wall water proofing refers to a technique used to prevent water infiltration to the structure of the wall. Over the past 30 Years polymer based waterproofing products have been developed. EPDM based product lasts for the entire lifetime of the building and are not affected by pH of the soil. EPDM based waterproofing material have the advantages of low viscosity thus, can be installed directly on the wall”.



MINING & CONSTRUCTION

"The underground constructions has witnessed a shift in preference from dry to wet and then to polymer based application in both tunneling and mining. Leaking water can cause serious damage to the structure. ZENA-SEAL carries excellent water-proofing capabilities and remains flexible with its use on most substrates like cement, wood, metal, adhesive and paints. It provides ease in cleaning and reduces maintenance cost with long life durability”.

GEO-MEMBRANE

"ZENA-SEAL remains highly flexible even at a low temperature (down to -25°C) which enables installation in all weather conditions. It can be stretched up to 300%, facilitating comfortable installation, even on challenging sub-grade temperatures and for extensive applications".



GREEN ROOFS USING ZENA-SEAL EPDM WATERPROOFING MEMBRANE

"ZENA-SEAL EPDM Waterproofing Membrane is widely used as a waterproof membrane for green roof construction because of its properties and resilience. Green roofs serve several purposes for a building such as absorbing rainwater, providing insulation, landscaping, and aiding to reduce urban air temperatures thereby combating the heat island effect".

POND LINING

Pond liners find crucial applications in addressing the global water scarcity challenge. Rainwater harvesting, essential for water conservation, benefits significantly from these liners. Many drought-prone regions have initiated robust rainwater harvesting programs due to their cost-effectiveness, durability, and longevity. Additionally, large pond liners play a vital role in supporting commercial activities such as fish farming, ensuring sustainable ponds with minimal maintenance. They are also instrumental in the lucrative business of pearl farming, associated with the fisheries industry.



FEATURES & COMPARISON

■ *The Superior properties of EPDM WATER PROOFING:*



The life of any building is dependent on the designer recognizing and considering all the factors relevant to its location, shape, and function of the building. Reliable roofing is the most important part, which decides the quality & ultimately the life of the building. An efficient roofing membrane should never allow even small traces of water to pass through at any given point and should maintain this characteristic over a long period of time. It should withstand slight movements of the structure, bad weather, chemical degradation and mechanical stress and strains.

EPDM sheet (with a thickness of 1.2 mm) is 22 times more powerful than asphalt and is 59 times more reliable waterproofing than PVC sheet.

■ *ZENA-SEAL will take the “movement” of the structure*



Since ZENA-SEAL sheet can be stretched (approx. 400%), it will not tear, crack or split but returns to the original position, without any damage to the membrane. ZENA-SEAL has an unflinching flexibility.

■ *ZENA-SEAL withstands extremes of temperature*



ZENA-SEAL, owing to its EPDM base polymer, maintains its performance consistently across a broad spectrum of temperatures (-40° C to +130° C). Hence it does not become brittle in freezing weather nor exhibit cracks in hot weather.

■ *ZENA-SEAL is minimal extra load on your roof*



ZENA-SEAL roofing sheet is one of the lightest roof membrane materials (with a specific gravity of approx. 1.25 kg/m²). It is highly suitable for lightweight structures and puts negligible extra load on roofs that are to be water proofed.

■ *ZENA-SEAL lasts for more than 20 Years*



Presently in our country, asphalt-based coating is employed in many buildings to protect the roof from leaking. However, the life of such waterproofing is limited, and the coating must be replaced every 2 to 3 years because of poor dimensional stability of asphalt in extreme temperatures. ZENA-SEAL EPDM Waterproofing membrane stands out for its exceptional water and weather resistance, ensuring longevity. With its excellent dimensional stability, these roofing membranes are crafted to endure for over 20 years.

FEATURES & COMPARISON

■ Maintenance Free Waterproofing

As the ZENA-SEAL EPDM Rubber Sheet does not deteriorate due to extreme weather, UV and oxidation, hence no maintenance is required for the roof.



■ Resistant to most of the acidic & alkaline conditions for wide range of temperature

As the EPDM rubber is highly saturated polymer, it has better chemical and environmental resistance than other available polymeric materials. Hence ZENA-SEAL can be used in chemical plants for their drainage and canal systems to avoid seepage through the RCC/CONCRETE work which in turn can damage surrounding fields. The following table shows the comparative properties of EPDM roof sheeting against other materials used for roof protection, which indicates superiority of EPDM roof sheeting.

COMPARISON OF ZENA-SEAL WITH OTHER WATER PROOFING TECHNIQUES

Properties	ZENA-SEAL EPDM Roofing ZSWP 100	PVC Roofing	Modified Bitumen Roofing	BUR Roofing (Bituminous built up Roofing)
UV resistance	E	P-F	F	G
Ozone resistance	E	E	F	F
High Temperature resistance	E	E	F	F
Cold Crack	E	F-G	P	P
Resistance to Plasticizer Migration	E	F-G	P	P
Dimensional	E	P-F	F	F
Install over existing roof.	YES	YES	YES	NO
NA = Not Applicable, E = Excellent, G = Good, F = Fair, P = Poor				

INSTALLATION INSTRUCTIONS



Step-1

Remove all of the existing roof material and metal flashing. Sweep all dirt and debris from the roof with the push broom.



Step-2

Inspect the roof surface for damage. Repair any damaged areas before installing the EPDM rubber membrane sheets.



Step-3

Lay insulation boards on the roof. Line the boards up flush to each other and butt the ends up together to ensure a uniform roof surface. Secure the insulation boards to the roof by attaching the insulation plates to the insulation boards. Insert galvanized screws through the insulation plates and attach the plates to the roof using the drill. Insert a plate and screw every 2 square feet of board.

Step-4

Sand any rough areas of the insulation board. Sweep all dirt and debris from the insulation board with the push broom before laying the EPDM rubber sheets.



Step-5

Roll out EPDM roofing membrane onto the roof. Overlap the side edges of each previously rolled sheet by 4 inches (0.10 Mtrs.). Overhang the edge of the roof by 3 inches (0.08 Mtrs.). Mark locations for vents & pipes access through the rubber. Allow the material to relax for 30 minutes before applying adhesive.

INSTALLATION INSTRUCTIONS



Step-6

Fold the first rubber sheet back on top of itself. Apply an even layer of bonding adhesive to the deck of the roof using the extension roller. Allow the adhesive to dry for 15 minutes until it is tacky to the touch. Fold the rubber sheet back over onto the roof deck. Smooth the sheet with the roof roller. Start from the centre of the sheet and work out. Roll over the sheet with a roof roller to smooth out air bubbles and wrinkles.

Step-7

Fold the second half of the sheet back onto the half that was previously glued down. Repeat step 6, but leave 4 inches (0.10 Mtrs.) of the edge without glue to follow for the seam. Fold the roofing membrane back onto the roof deck. Roll over the sheet with the roof roller to smooth out air bubbles and wrinkles.



Step-8

Repeat step 6 and 7 to bond all of the roofing membrane sheets of the roof. Allow the sheets to cure for an hour. Roll over the entire roof with the roof roller to remove wrinkles and ensure an airtight seal.

Step-9

Measure 1 inch (0.025 Mtrs.) beyond the edge of the overlap of the first sheet. Fold the sheet back to expose the 4 inches (0.10 Mtrs.) of unglued rubber. Use a paint brush to apply seam primer to the 4 inch (0.10 Mtrs.) section and to the area on the sheet that it will mate with.



Step-10

Attach the roof tape to the first sheet with the adhesive side down, facing the base sheet. Roll over the tape with the seam roller. Fold the overlapping sheet back down the base sheet. Slowly peel the backing from the tape at a 45 degree angle while simultaneously pressing the top rubber sheet down into the tape. Roll the seam roller over the taped seam to bond it.

Step-11

Repeat Step 9 and 10 until every seam has been bonded and secured.

STORAGE & SHIPPING

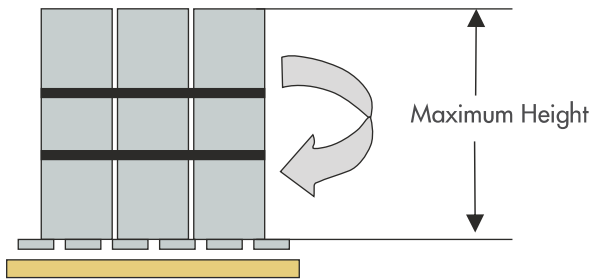

Large Rolls

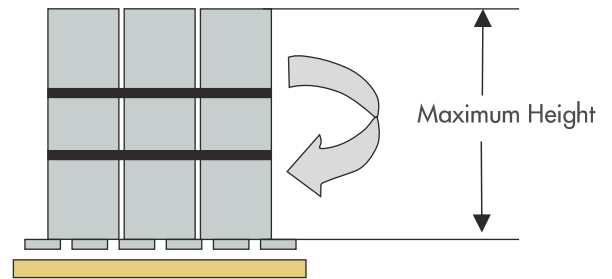

Short Rolls

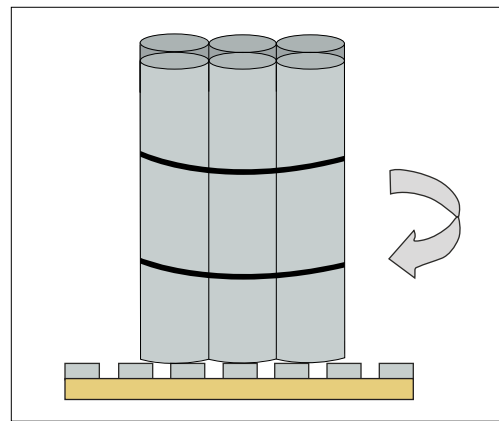
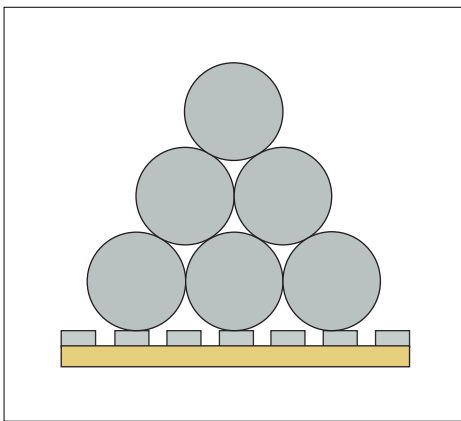
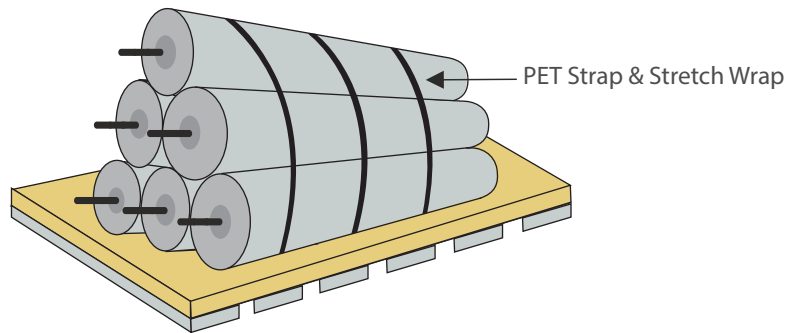

All material must be secured to the pallet in such a manner as to prevent shifting according to diagram below. Metal banding is not to be used.

All rolled material must be inside of pallet .

All material must be placed on a pallet large enough so there is no overhanging material on any side.

Shrink wrapped and strapped with plastic strapping "NO METAL BONDING"

ACHIEVEMENTS & MEMBERSHIP

- AIRIA Highest Export Award - 2022-2023.
- Best Exporter Gold Trophy Award - FIEO.
- Special Export Award - Capexil.
- State Export Award - Directorate of Industries
- Certificate of Merit Maharashtra Government.
- Membership with AIRIA (All India Rubber Industries Association)
- Membership with CAPEXIL (Chemical and Allied Export Promotion Council of India Limited)
- Membership with FIEO (Federation of Indian Export Organisations)
- Membership with IMC (Indian Merchant Chamber)
- Certificate of Government Recognized Export House



ISO 14001 : 2015



ISO 9001 : 2015



45001:2018



सत्यमेव जयते
DSIR



NABL

SYSTEM CERTIFICATE

ISO 9001:2015

ISO 14001:2015

ISO 45001: 2018

DSIR CERTIFICATION

NABL ISO 17025

PRODUCT CERTIFICATION

CE Certificate

RoHS Intertek Compliance

RoHS - TUV

PAH Compliance

REACH Compliance

US-FDA Certification

WRAS Certificate

WQC Certificate

SVHC Compliance

Chemours Genuine Viton Distributor



FRAS



A Partner of Viton™
a Brand of The Chemours Company

Zenith Rubber enjoys the leadership status
with their wide Presence & Network
across the globe



ZENITH™ **ZENITH** INDUSTRIAL RUBBER
PRODUCTS PVT. LTD.
Quality Rubber Solutions



www.zenithrubber.com

141-144, Free Press House, Free Press Journal Marg 215,
Nariman Point, Mumbai - 400 021

Contact No : +91-22 22885888 / 31001400 | Fax : 91-22 22885222

Email: info@zenithrubber.com (International) | sales@zenithrubber.com (Domestic)

